

## Samovrtné šrouby

Přehled  
samovrtných šroubů  
EJOFAST®

JF2-2-4,2

JF2-2H-4,8

JF3-2H-4,8

JF3-2-5,5

JF3-2-6,0

JF3-Plus-4,9

JF3-Plus-6,8

Šrouby  
s inovativní geometrií  
vrtací špičky

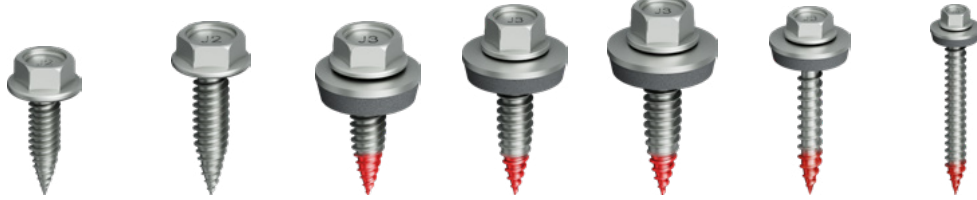

**Materiál**

Ocel zušlechťená  
s ochranou proti korozi

Nerez A2 s kalenou  
ocelovou vrtací špičkou

**Pro dílce z**

Ocel

Ocel nebo hliník

Ocel nebo hliník na dřevo

**Max. vrtací kapacita  
do oceli [mm]**

0,75 + 0,75

0,88 + 0,88

0,88

Přehled samovrtných  
šroubů

JT2

JT3

JT6

JT4

JT9

Samovrtné šrouby  
s klasickou vrtací  
špičkou



**Materiál**

Ocel zušlechťená  
s ochranou  
proti korozi

Nerez A2  
s kalenou ocelovou  
vrtací špičkou

Nerez A4  
s kalenou ocelovou  
vrtací špičkou

Nerez A2

Nerez A4

**Pro dílce z**

Ocel

Ocel nebo hliník

Hliník

**Max. vrtací kapacita  
[mm]**

18,0





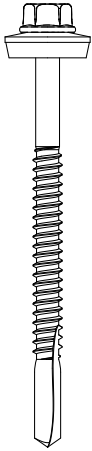

6,0

## Samovrtné šrouby

### Stanovení technických specifikací

na příkladu samovrtného šroubu JT3-12-5,5x78 E16



Hlava	Těsnící podložka	Průměr	Délka	Svěrná tloušťka	Vrtací kapacita	Otáčky
 SW8	 E16	 5,5	 78	 25–51	 DC $t_t + t_{tr}$ 2,0 + 10,0	 1/min max. 1300

Skupina výrobků	Jmenovitý průměr [mm]	Vrtací kapacita DC [mm]	Otáčky [1/min]
JF2 / JT2 / JF3 / JT3 / JT4 / JF6 / JT6 / JT9	4,8 / 4,9 / 5,5 / 5,6 / 6,0 / 6,3 / 6,5 / 6,8	≤ 3	max. 1800
		3–8	max. 1500
	8,0	≥ 8	max. 1300
		≤ 3	max. 1300

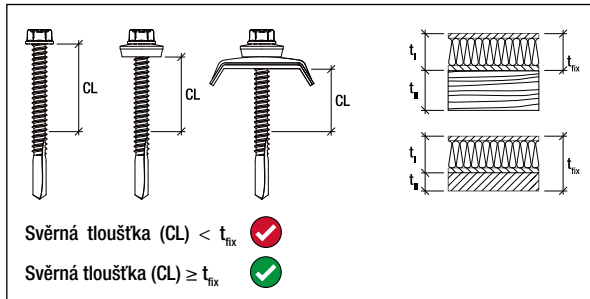

### Upozornění



Z-14.4-901  
Z-14.4-426  
Z-50.4-337  
Z-10.3-833



ETA-10/0200  
ETA-13/0177  
ETA-22/0126  
ETA-24/0547



Technická pravidla  
pro lehké kovové  
konstrukce



Ochrana zraku



Do montáže  
chránit před  
vlhkem



Neodřezávat  
vrtací špičku!

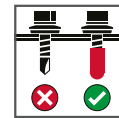

Použít krytku  
závitů

# Samovrtné šrouby

## Postup montáže (příklad 1)

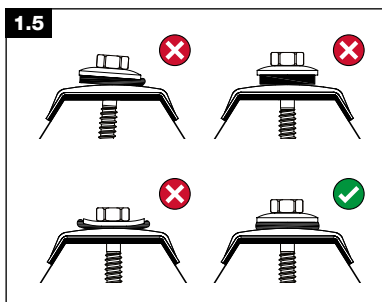
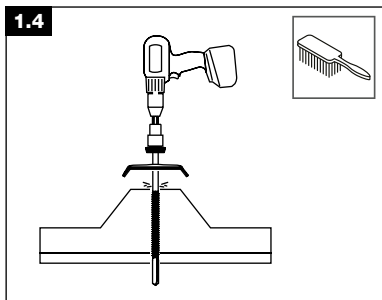
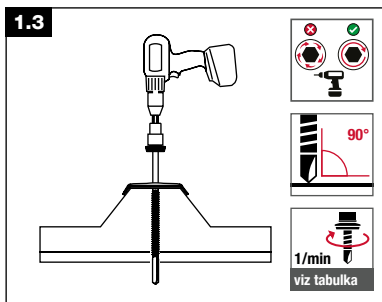
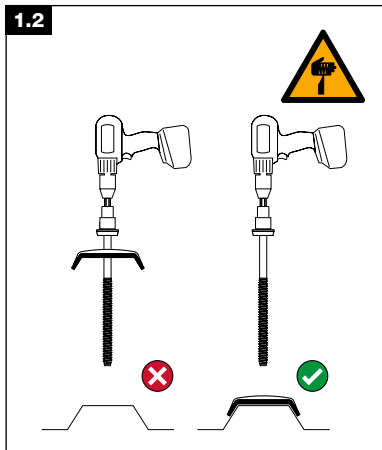
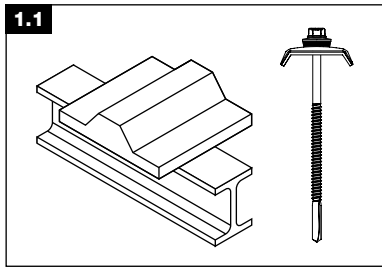

## Postup montáže (příklad 2)

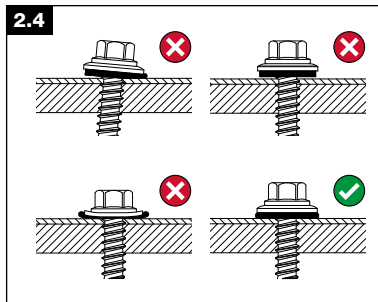
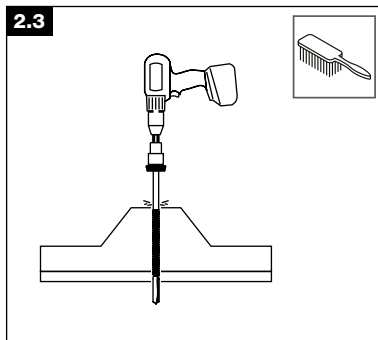
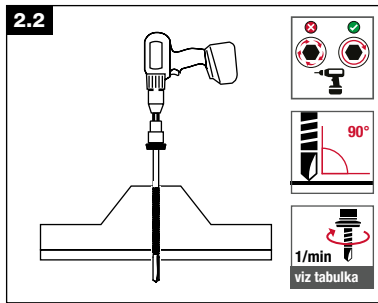
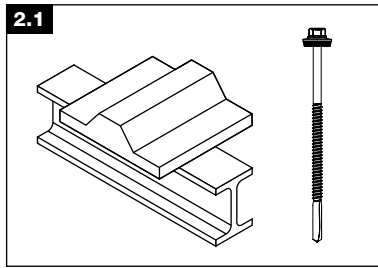

## Postup montáže (příklad 3)

